

Soda Can Calorimeter

Energy Content of Food



Introduction

Have you ever noticed the nutrition label located on the packaging of the food you buy? One of the first things listed on the label are the calories per serving. How is the calorie content of food determined? This activity will introduce the concept of calorimetry and investigate the caloric content of snack foods.

Concepts

- Calorimetry
- Conservation of energy
- First law of thermodynamics

Background

The law of conservation of energy states that energy cannot be created or destroyed, only converted from one form to another. This fundamental law was used by scientists to derive new laws in the field of *thermodynamics*—the study of heat energy, temperature, and heat transfer. The *First Law of Thermodynamics* states that the heat energy lost by one body is gained by another body. Heat is the energy that is transferred between objects when there is a difference in temperature. Objects contain heat as a result of the small, rapid motion (vibrations, rotational motion, electron spin, etc.) that all atoms experience. The temperature of an object is an indirect measurement of its heat. Particles in a hot object exhibit more rapid motion than particles in a colder object. When a hot and cold object are placed in contact with one another, the faster moving particles in the hot object will begin to bump into the slower moving particles in the colder object making them move faster (vice versa, the faster particles will then move slower). Eventually, the two objects will reach the same equilibrium temperature—the initially cold object will now be warmer, and the initially hot object will now be cooler. This principle is the basis for *calorimetry*, or the measurement of heat transfer.

In the 1770s, Joseph Black (1728–1799) was one of the first scientists to conduct calorimetry experiments with different materials. He discovered that not all materials are equal when it comes to heat transfer. He concluded that different materials have their own unique ability to retain heat energy. Some materials, like water, can gain a large amount of heat energy without a significant change in temperature, while other materials, such as metals, will have a more dramatic temperature change for the same amount of heat energy gained. This property is based mainly on the structure of the material, the size of the atoms and molecules, and the interactions between them. This is known as the *specific heat* of the substance. The specific heat is defined as the heat energy required to raise the temperature of one gram of a substance by one degree Celsius. The unit of energy commonly associated with heat is called a *calorie*. Water has a defined specific heat of 1 cal/g °C so it takes one calorie of energy to raise the temperature of one gram of water by one degree Celsius. (The reverse is also true, remove one calorie of heat from one gram of water, and the temperature will decrease by one degree Celsius.) With the specific heat of a substance known, the amount of heat energy gained or lost by a substance can then be calculated if the temperature change is measured.

In this experiment, the specific heat of water and its change in temperature will be used to determine the caloric content of a food sample. The normal unit for measuring the energy content in food is called a Calorie (with an uppercase C). A Calorie is really a kilocalorie, or 1000 calories (lowercase c). During calorimetry, food burns and its stored energy is quickly converted into heat energy and products of combustion (carbon dioxide and water). The heat energy that is released is then transferred into the water above it in the calorimeter. The temperature change in the water is then measured and used to calculate the amount of heat energy released from the burning food. The heat energy is calculated using Equation 1.

$$Q = mC\Delta T \quad \text{Equation 1}$$

where

Q = heat energy

m = mass of the water

C = specific heat of the water

ΔT = change in water temperature, $T_{\text{final}} - T_{\text{initial}}$
("Δ" is the Greek letter Delta which means "change in")

Materials

Balance (0.01-g precision)
Cork stopper
Butane safety lighter
Graduated cylinder, 50-mL
Metal ring with clamp
Pin, large straight
Ruler, metric

Snack foods (cheese puffs, popcorn, marshmallows, etc.)
Soda can, empty and clean
Stirring rod, glass
Support stand
Thermometer
Water, distilled or tap, 50 mL

Safety Precautions

Wear safety glasses when performing this or any lab that uses chemicals, heat or glassware. Care should be taken when handling or placing food onto the pin point. Allow the food sample to cool before touching or discarding it. Use a glass stirring rod to stir the liquid; never stir with a thermometer. Students should not be allowed to eat the snack foods once they are brought into the lab. This lab should be performed in a well-ventilated room. Wash hands thoroughly with soap and water before leaving the laboratory.

Procedure

1. Push the pin through the cork so that the pin head is flush with the cork. If the pin is large enough, try to go through the center. If this is hard to do, try to insert the pin at an angle through the side and top of the cork (see Figure 1). *Note:* This setup will now be referred to as the “Food Holder.”
2. Place a food sample on the food holder. Measure and record the combined mass of the food holder and sample. Place the food holder on the base of a support stand.
3. Using a graduated cylinder, measure and add 50.0 mL of water to an empty, clean soda can.
4. Bend the tab on the soda can and slide a glass stirring rod through the hole. Suspend the can on a support stand using a metal ring (see Figure 2). Adjust the height of the can so that it is about 2.5 cm above the food holder.
5. Insert a thermometer into the can. Measure and record the initial temperature of the water.
6. Light the food sample and center it under the soda can. Allow the water to be heated until the food sample stops burning. Record the maximum (final) temperature of the water in the can.
7. Measure and record the final mass of the food holder and sample.
8. Allow the can and pin to cool, and then clean the bottom of the can and remove any food residue from the food holder.
9. Repeat steps 1–8 two more times with two different snack food samples.

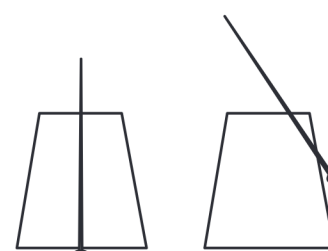

Figure 1.

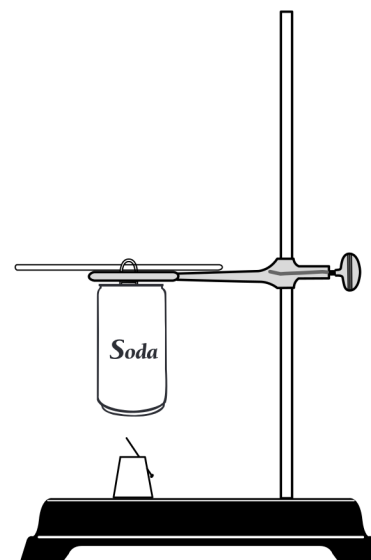

Figure 2.

Disposal

Please consult your current *Flinn Scientific Catalog/Reference Manual* for general guidelines and specific procedures, and review all federal, state and local regulations that may apply, before proceeding. Burned food samples should be allowed to cool and may be disposed of in the trash according to Flinn Suggested Disposal Method #26a.